

CUSTOM PADS FROM



FULL CIRCLE
P A D D I N G . c o m
S I N C E 1 9 8 5

HOW TO MEASURE:

Remove pad from machine for accurate hole placement. Once pad is removed identify top (head end) of plywood. All measurements are in inches.

- A Actual length of wood
- B Width of wood at (head end)
- C 2nd width of wood if different than B
- D Distance from edge to center of first hole (hole 1)
- E Distance from adjacent edge to center of first hole
- F Distance between holes (center to center)
- G Distance between holes (center to center)
- H Distance between holes (center to center)
- J Distance between holes (center to center)
- K Foam size is 3/4", 1", 1-1/4" 1-1/2" and 2". Do not include board thickness in your measurement. Standard plywood is 3/4"
- L Specify bolt diameter. 1/4", 5/16", 3/8", M8, M10

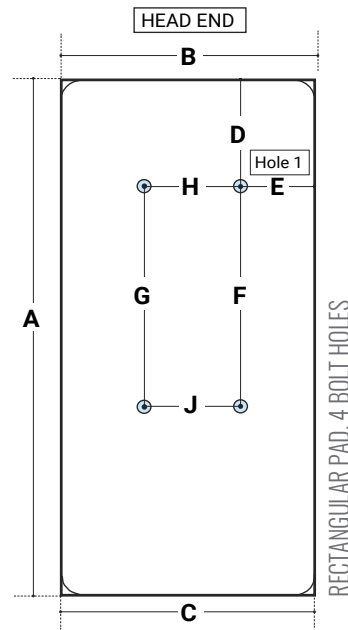
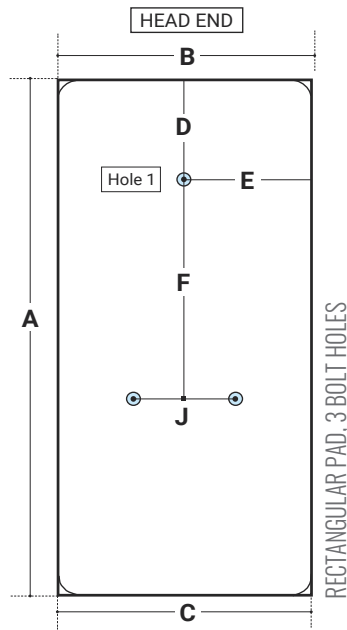
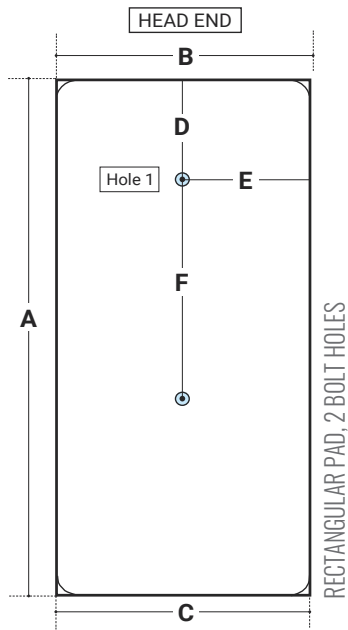

ALL HOLE MEASUREMENTS ARE TO THE CENTER OF THE BOLT HOLE

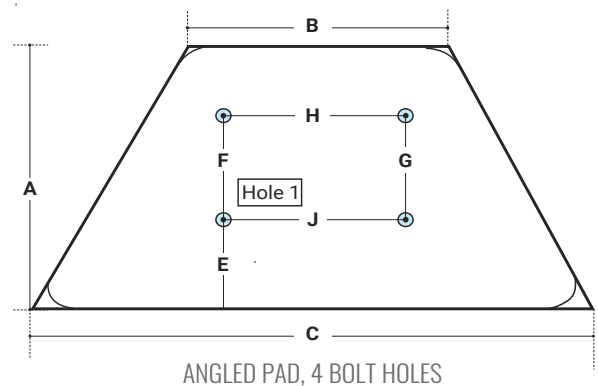
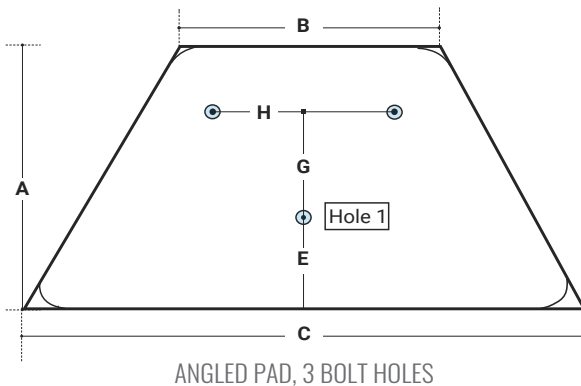
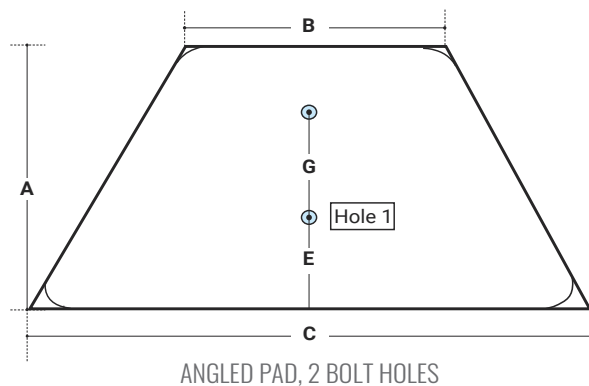

ROLLER MEASUREMENT



Remove roller from the machine to get an accurate length. Please measure and put dimensions on pad order sheet:

1. Length of roller - measure inner length
2. Diameter of shaft roller rides on
3. Outer diameter of roller

BOLT DIAMETER

Measure the diameter of your bolts, typically 1/4", 5/16", 3/8", M8 or M10

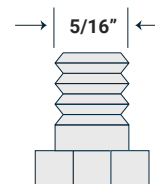

SUBMIT YOUR PAD DIAGRAMS

Use the next page to create a detailed diagram of your pad with measurements (one for each pad). Once completed, please email to:

brian@fullcirclepadding.com



CUSTOM PAD ORDER FORM

YOUR INFORMATION

Company Name _____
 Contact _____
 Address _____
 City, State, Zip _____

Date _____
 Phone Number _____
 Email _____
 Customer ID _____

Using the instructions on the previous page, please measure the pad for which you need a replacement and draw a diagram with the measurements in the space provided. Please call with any questions: 1-800-875-7780.

Email the completed form(s) to **brian@fullcirclepadding.com**

PAD DIAGRAM PLEASE COMPLETE ONE SHEET FOR EACH PAD BEING ORDERED

Foam Size _____

Bolt Thread Size _____

Your diagram should have the measurements filled in like the samples below:

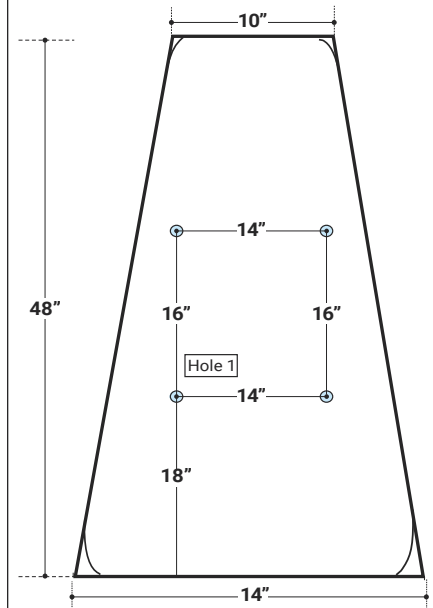

MACHINE & PAD INFORMATION

Manufacturer _____
 Machine _____
 Model # _____

Pad Position _____
 (head, back, seat, chest, shoulder, elbow, arm, thigh, shin, ankle)
 Color _____

Complete Pad Wear Cover Only

Please note: 3/4" Plywood is standard