

Technical Procedure

Glute Drive Seatbelt Replacement

Applies to: Glute Drive (9NP-L1131)

Please see below to determine if the adapter kit needs to be installed as well as the instructions for replacing the belt.

Required Parts:

- NA855 Seat Belt with Adapter Kit, GLUTE DRIVE

Required Tools:

- 16mm Socket
- 16mm Open-ended Wrench
- 5mm Allen Key

Visually inspect the Glute Drive seatbelt attachment point to determine if the adapter kit is needed - See matrix below:

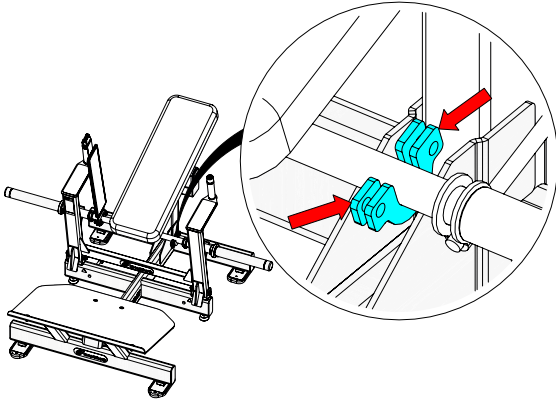
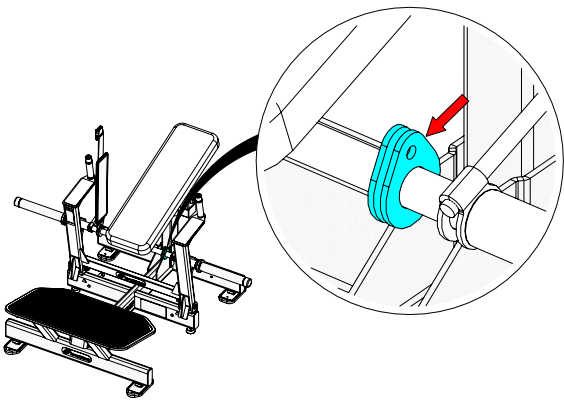
Seatbelt Attachment Point Design	Adapter Kit Needed?
 <p data-bbox="272 1423 695 1476"><i>Half-Moon, Double-Point Attachment BEFORE S/N: NPL1131-L18121032</i></p>	<p data-bbox="878 1087 1409 1402">YES See - Page 2, Step 1</p>
 <p data-bbox="285 1913 683 1965"><i>Teardrop, Single-Point Attachment AFTER S/N: NPL1131-L18121031</i></p>	<p data-bbox="878 1577 1409 1892">NO See - Page 3, Step 1</p>

Technical Procedure

Half-Moon, Double-Point Attachment:

1. Use a 16mm socket and a 16mm open-ended wrench to remove the hardware securing the left side belt to the weight bar.

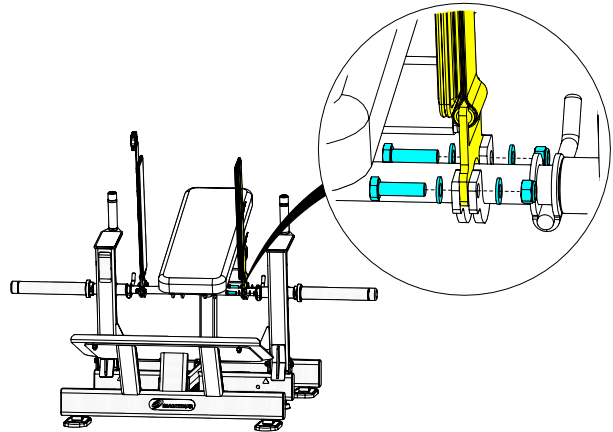

2. Place one adapter plate between the two belt mount brackets on the weight bar and the other adapter plate on the outside of the outer mounting bracket.

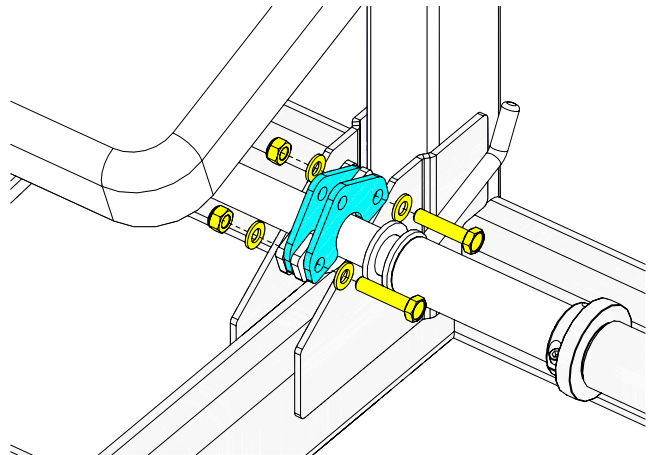

3. Use a 16mm socket and a 16mm open-ended wrench to install the two (2) pieces each of the M10 x 45mm bolts and M10 nuts, and four (4) pieces of the M10 washer but **DO NOT FULLY TIGHTEN**

4. Use a 5mm allen key and a 16mm open-ended wrench to secure the belt to the adapter using one (1) piece each of the M8 nut, M8 washer, and M10 x 16mm shoulder bolt.

5. Use a 16mm socket and 16mm open-ended wrench to fully tighten the hardware installed in Step 3.

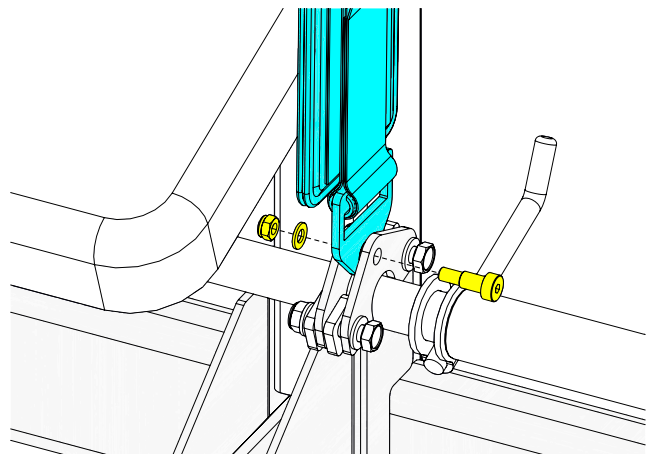

Technical Procedure

Teardrop, Single-Point Attachment:

1. Use a 5mm allen key and a 16mm open-ended wrench to secure the belt to the weight bar belt mount using one (1) piece each of the M8 nut, M8 washer, and M10 x 16mm shoulder bolt.

